

Offline pump & filter

Your guarantee for problem-free hydraulics

Technical information CM-101



Contaminated oil is one of the main causes of operating faults in hydraulic systems and can significantly impact the service life of equipment.

MacGregor's offline filtration unit filters the hydraulic oil in a separate circuit using a high-capacity filter element. The unit extends the usable life of oil by relieving the oil filters in the main flow and reducing water and solids contamination.

The unit is installed close to the main hydraulic tank and operates independently of the main hydraulic system to provide 24-hour continuous filtration.

The filtration unit is suitable for crane types with oil tank volumes up to 1,000 litres and includes: an electric motor, an electric switch with overload protection, a 10m electric cable, a hydraulic pump and a filter holder; all of which are pre-mounted on a steel plate for easy installation onto the crane. All necessary hydraulic hoses and couplings are included.

The electric cable connects to a separate feed with its own power supply to ensure continuous operation even

when the crane is not running. If the oil is too cold or the filter element is dirty, a manometer will indicate a pressure drop inside the filter cartridge. In response, a pressure relief valve will divert the oil. The pressure gauge displays the pressure level before and after a cartridge change to facilitate easy measuring of the pressure and sampling of oil.

To allow the filter cartridge to be changed, a clearance of 400mm should be reserved during installation.

Benefits

- Eliminates/dramatically reduces both solid and water contaminants
- Increased oil purity improves crane reliability and lifetime of hydraulic components
- Fewer oil changes
- Separate filter system with constant pressure and low flow provides extremely efficient filtration
- An optional thermostat can be fitted to the system to facilitate an automatic start/stop function
- The unit is delivered complete with all the necessary mechanical, hydraulic and electrical parts, together with installation instructions

At your service



MACGREGOR

Designed to perform with the sea

Filter unit

Pump displacement:	1.0cc/rev
Nominal flow:	1.2l/min (at 50Hz) 1.4 l/min (at 60Hz)
Maximum oil temperature:	+80°C
Viscosity range:	20 to 180cSt
Electric motor:	230VAC 50/60Hz
Power consumption:	0.18kW
Weight:	19kg

A standard cellulose filter cartridge is included in the delivery:

Maximum viscosity:	180cSt
Minimum temperature ISO-VG 68:	approximately +20°C
Minimum temperature ISO-VG 100:	approximately +25°C
Filter efficiency:	$\beta_{0.5} > 200$
Water collection capacity:	85 - 150ml/cartridge
Minimum replacement interval:	six months
Filter cartridge:	cellulose material

For cold climates, a special filter cartridge can be ordered separately:

Maximum viscosity:	800cSt
Minimum temperature ISO-VG 68:	approximately +5°C
Minimum temperature ISO-VG 100:	approximately +10°C
Filter efficiency:	$\beta_{1.0} > 200$
Water collection capacity:	no
Minimum replacement interval:	no

Ordering information

189 6208-801	Installation, crane type G
189 6207-801	Installation, crane type GL
1236440	Installation, crane type GLB
875 29001-010	Filter cartridge, standard/cellulose
875 29001-011	Filter cartridge, optional/fibreglass

Dimensions

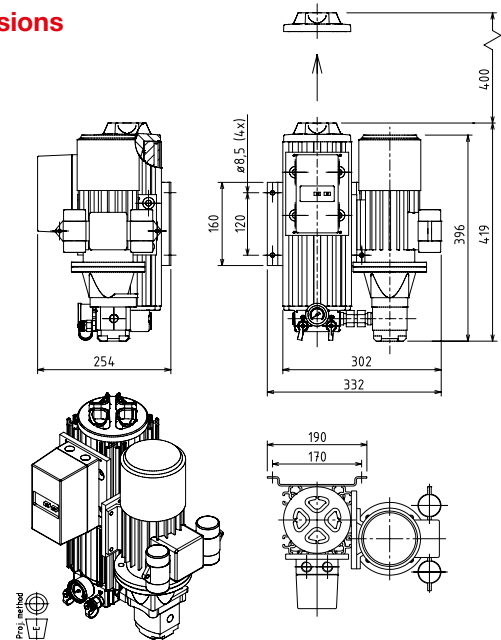

Hydraulic circuit

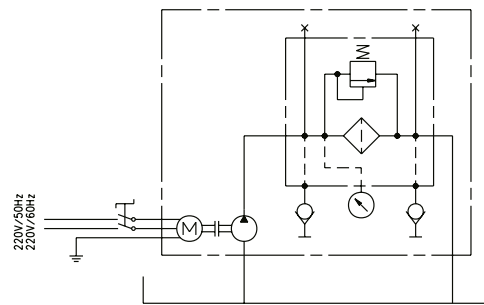

Installation requirements

Personnel required:	an engineer
Installation time:	approximately 2 to 4 hours/crane
Tools required:	standard hand tools and welding equipment for brackets

MacGregor solutions and services for handling marine cargoes, vessel operations, offshore loads, crude/LNG transfer and offshore mooring are all *designed to perform with the sea*.

MacGregor is part of Cargotec (Nasdaq Helsinki: CGCBV).

Published by MacGregor. Copyright © MacGregor January 2018. All rights reserved. No part of this publication may be reproduced, stored, photocopied, recorded or transmitted without permission of the copyright owner.